

**INTELLIGENT  
FLOOR™**



**AFC**

ACS/Uni-Fab

2505 Merritt Drive  
Garland, TX. 75041-6146  
Tel : (972) 278-3888  
Fax : (972) 278-8585  
[www.afcweb.com/uni-fab](http://www.afcweb.com/uni-fab)

## AFM35 w/ WHIP END EXTENDER CABLE

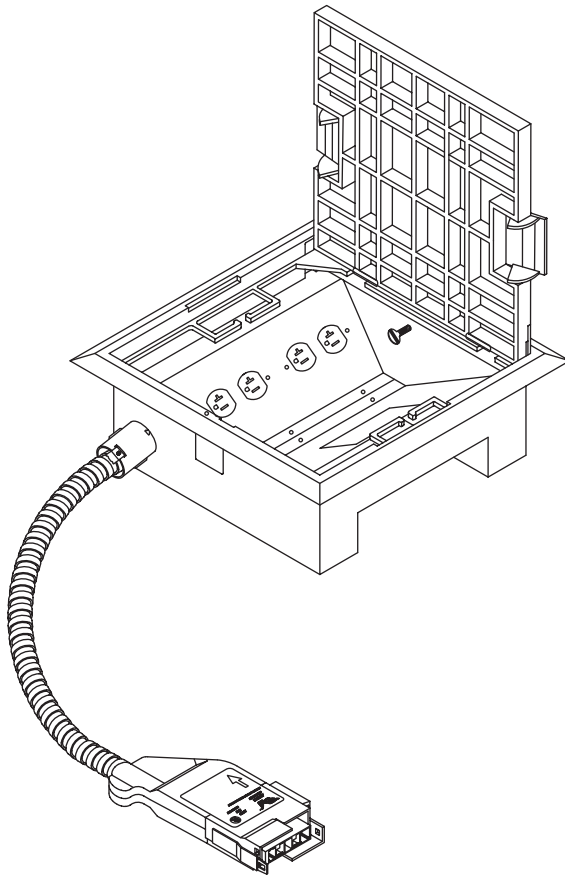

### Description

The AFM35 series Access Floor Module provides both power and telecommunication compartments for raised floors with a minimum height of 3-1/2 inches. The power compartment is designed for two (2) duplex receptacles, and the telecomm compartment can accept 2 duplex data plate which can accommodate up to 6 data ports. The lid is suitable for both carpet and tile applications.

The AFM35 series Access Floor Box can be provided with normal power, isolated ground power or both normal and isolated ground power. Branch circuit power is carried through a Whip End Extender Cable to the AFM.

Whip End Extender Cables are manufactured with Type MC Cable and feature 90° C insulated #12 AWG, solid copper conductors and a #12 AWG solid copper ground.

Whip End Extender Cables are rated for use on 20 ampere branch circuits and are keyed and color-coded according to specific voltage requirements.

Dimensions for the AFM35 Series Access Floor Box is 3-1/2 inches deep x 8 inch square. Access Floor Box requires an 8-5/8" x 8-5/8" ± 1/16" floor panel opening for proper installation.

### Catalog Number

AFM 35 - 2GP - 0IG - EA - \*W

